

## Product Features

1. Ultra small 32.768 KHz RTC Oscillator in seam sealed ceramic package.
2. 4 pads design to achieve good soldering contact on PCB
3. Use AT crystal as the resonator for good temperature performance
4. Tri-State function available for power saving
5. RoHS and REACH Compliant , Pb-free , Halogen-free
6. Industry Standard Package :  
2.5 x 2.0 x 0.8 mm

Application :

- Real Time Clock
- System in sleep mode or low energy mode timekeeping

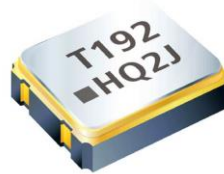

Test condition  
Ambient temperature :  $25 \pm 5^{\circ}\text{C}$   
Relative humidity : 40% ~ 70%

● Table 1 . Electrical Specifications

Parameters	Symbol	Min.	Typ.	Max.	Units	Notes
<b>Frequency Range and Stability</b>						
Nominal Frequency	F	32.768			KHz	
Frequency Tolerance	FT	$\pm 25$			ppm	@ -40~85°C , Note 1
		$\pm 30$				@ -40~105°C , Note 1
		$\pm 50$				@ -40~125°C , Note 1
<b>Operating Temperature Range</b>						
Operating Temperature	Topr	-40	25	125	°C	
<b>Supply Voltage and Current Consumption</b>						
Supply Voltage	Vdd	1.62 ~ 3.63			V	
Current Consumption	Icc			0.5	mA	CL=15pF
Standby Current	Icc(ST)	-	-	20	uA	OE = Low
<b>CMOS Type Signal Characteristics</b>						
Output Load : CMOS	CL	15			pF	
Output Voltage High	VoH	90%Vdd	-	-	V	
Output Voltage Low	VoL	-	-	10%Vdd	V	
Rise Time	Tr	-	-	20	ns	10% → 90% Vdd Level
Fall Time	Tf	-	-	20	ns	90% → 10% Vdd Level
Symmetry (Duty ratio)	TH/T	45	~	55	%	
<b>Aging Performance</b>						
Aging	-	$\pm 3$			ppm/yr.	1st. Year at 25°C
<b>Startup and Resume time</b>						
Start-up Time	Tosc	-	-	3	ms	To 90% of Final Amplitude

Note 1 : Inclusive of frequency tolerance at 25°C , variation over temperature, supply voltage variation, aging and vibration.

Note 2 : The table shows common spec. if you have special spec. requirement , please feel free to contact our salesperson.

Test condition  
Ambient temperature :  $25 \pm 5^{\circ}\text{C}$   
Relative humidity : 40% ~ 70%

● **Table 1 . Electrical Specifications (continued)**

Parameters	Symbol	Min.	Typ.	Max.	Units	Notes
<b>Enable Pin Control and Input Characteristics</b>						
Enable Control	-	Yes			-	Pad 1
Enable Voltage High	V <sub>IH</sub>	70%V <sub>dd</sub>	-	-	V	
Disable Voltage Low	V <sub>IL</sub>	-	-	30%V <sub>dd</sub>	V	
<b>Aging Performance</b>						
Aging	-	$\pm 3$			ppm/yr.	1st. Year at 25°C

● **Test Diagram**

Pad 1(OE)	Pad 3 (Output)	Oscillator
High (or open)	OSC out	Normal operation
Low	High impedance	Stop oscillation

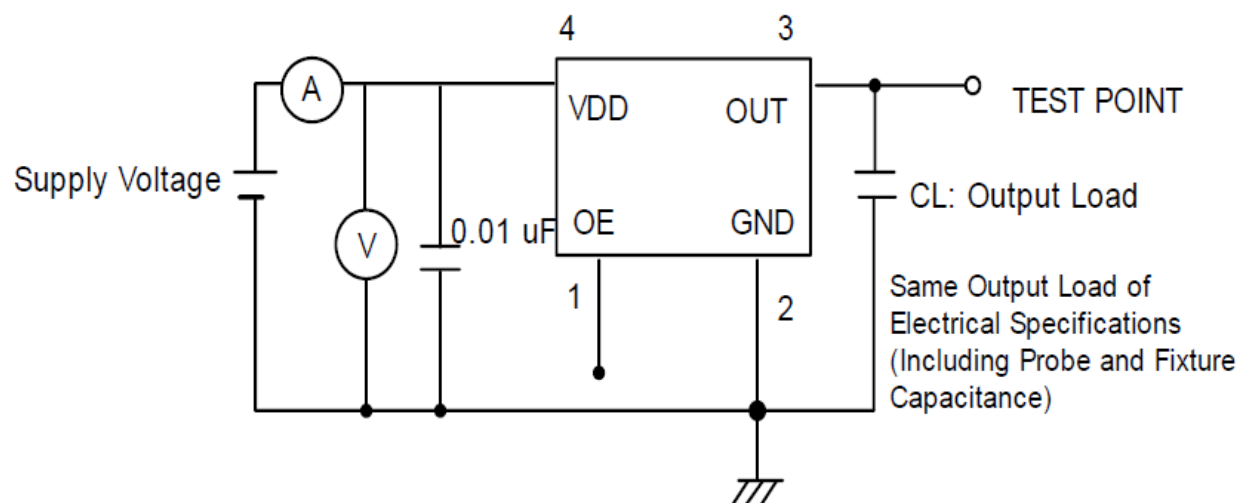

Note : TXC sets CL to 15pF for simulation IC load. Customer does not need to layout it in reality circuit.

● **Waveform Conditions**

Waveform measurement system should have a min. bandwidth of 5 times the frequency being tested.

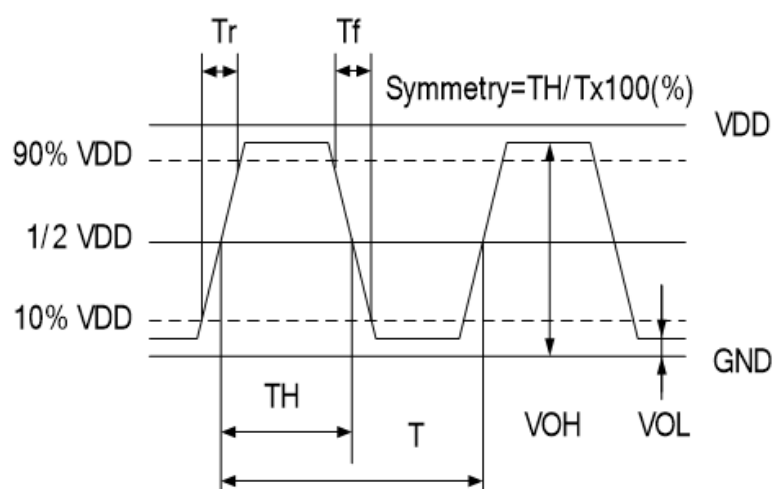

● **Dimensions & Footprint (Recommended)**

Unit : mm

